

Bond House 9-10,
Lower Bridge St, Dublin 8.
D08TH76

T: +353 1 9697881
E: Dublin@alantraynor.com
W: www.alantraynor.com

Unit 6, Belturbet Business Park,
Creeny, Belturbet, Co. Cavan.

T: +353 49 9522236
E: info@alantraynor.com
W: www.alantraynor.com



Alan Traynor Consulting Engineers Ltd.



Alan Traynor Consulting Engineers Ltd



Comhairle Chontae Liatroma
Leitrim County Council

**PROPOSED DEVELOPMENT AT LAHARD,
BALLINAMORE, CO. LEITRIM**

Foul, Surface Water, Attenuation Calculation & Details

Foul sewer loadings for Ballinamore, Co.L Leitrim

DATA										SEWER DESIGN Ks = 1.50									
SEWER REFERENCE From To Manhole	Manhole No.	HOUSES No.	UNITS/HOUSE No.	UNITS No.	UNITS l/s	TOTAL UNITS	TOTAL FLOW l/s	Size of drain (mm)	Gradient (1 in x)	Length (m)	Capacity (l/sec)	Pipe full Velocity (m/sec)	Actual Velocity (m/sec)	Half full velocity (m/sec)	Self cleansing at half full	Max Velocity (m/sec)	Depth of flow (mm)	Reserve capacity (l/sec)	
1	2	3	4	5	56	6	7	8	9	10	11	12	13	14	15	16	17	18	
Fext	F1	4	14	56	56	6	3.487	150	60.0	2.752	20.000	1.132	0.847	1.132	OK	1.291	42.188	16.513	
F2	F3	3	14	42	98	6	3.939	150	60.0	24.177	20.000	1.132	0.877	1.132	OK	1.291	45.703	16.061	
F3	Fnew	3	14	42	42	4	3.267	150	21.0	17.669	33.876	1.917	1.204	1.917	OK	2.186	31.641	30.609	
		4	14	56	196	4	4.661	150	20.0	38.580	34.715	1.964	1.362	1.964	OK	2.240	37.500	30.054	

3.487 l/s added from existing 4 houses

Storm sewer loadings for Development in Ballinamore, Co. Leitrim

DATA		STORM WATER FLOW Modified Rational Method				SEWER DESIGN Ks = 0.60															
SEWER REFERENCE		Roofs/yards Area A1		Impervious Area		Cumulative Impervious Area		Rainfall : I (mm/hr)	Storm Water Flow (l/sec)	Cr = 1.3 Cv = 0.7	Size of drain (mm)	Gradient (1 in x)	Length (m)	Capacity (l/sec)	Pipe full Velocity (m/sec)	Actual Velocity (m/sec)	Half full velocity (m/sec)	Max Velocity (m/sec)	Depth of flow (mm)	Reserve capacity (l/sec)	
From Manhole	To Manhole	Area A1	Area A2	Area A1	Area A2	Area A1	Area A2														
1	2	3	4	5	6	7	8														
S1	S3	0.018	0.019	0.037	0.037	50.00	50.00	4.62	4.62		225	47	23.863	76.01	1.91	1.06	1.91	2.17	37.79	71.39	
S2	S3	0.014	0.018	0.032	0.032	50.00	50.00	4.05	4.05		225	22	20.410	111.35	2.80	1.34	2.80	3.18	29.00	107.31	
S3	S4	0.028	0.027	0.055	0.123	50.00	50.00	15.56	15.56		225	20	34.188	116.82	2.94	2.06	2.94	3.33	55.15	101.26	
S4	Sout	0.000	0.000	0.000	0.123	50.00	50.00	4.00	4.00		225	200	0.000	36.57	0.92	0.61	0.92	1.04	50.10	32.57	

4.0 l/s achieved by means of a hydrobrake

Existing Flow for Site for Ballinamore, Co.Leutrim

RUNOFF ESTIMATION METHODS

EQUATION - $QBAR = 0.00108 * (AREA)^{0.89} * (SAAR)^{1.17} * (SOIL)^{2.17}$

AREA	3566	m2
SAAR	1268	mm
SOIL	0.4	index

QBAR	0.00419	m3/s
------	---------	------

Outflow **4.19** l/s
Outflow **11.74** l/s/ha



GENERAL DATA

site location: **Ireland**
 60 min rainfall depth of 5 year return period 'R' [mm] = **15**
 M5-60 to M5-2d rainfall ratio 'r' = **0.40**
 proposed discharge rate 'v₁' [litre/s] = **4.00**
 proposed discharge rate 'v₂' [litre/s] = **4.00**
 allowance for climate change: **10%**

SUMMARY OF CALCULATIONS

required storage volume for discharge rate 'v₁' = **21.76** m³
 required storage volume for discharge rate 'v₂' = **35.78** m³

AREA DATA

	impermeability [%]	effective area [m ²]
impermeable area 'A ₁ ' [m ²] = 1230	100.00	1230
landscaping and/or green roof area 'A ₂ ' [m ²] = 0	90.00	0
other partially permeable area 'A ₃ ' [m ²] =	100.00	0

AREA DRAINED TO ATTENUATION TANK = 1230 m²

REQUIRED STORAGE VOLUME PER RAINFALL DURATION FOR DISCHARGE RATE v₁

rainfall duration [min]	rainfall factor Z1	M5-D rainfalls [mm]	M10-D			M20-D			M30-D			outflow from attenuation tank [m ³]	required storage [m ³]
			Z2	rainfalls [mm]	inflow [m ³]	Z2	rainfalls [mm]	inflow [m ³]	Z2	rainfalls [mm]	inflow [m ³]		
5	0.37	6.10	1.17	8.20	10.09	1.36	10.10	12.42	1.45	11.40	14.02	1.20	12.82
10	0.52	8.40	1.18	11.40	14.02	1.38	14.10	17.34	1.47	15.90	19.56	2.40	17.16
15	0.63	9.90	1.19	13.40	16.48	1.39	16.60	20.42	1.49	18.70	23.00	3.60	19.40
30	0.80	12.70	1.20	17.00	20.91	1.39	20.90	25.71	1.49	23.50	28.91	7.20	21.71
60	1.00	16.20	1.20	21.50	26.45	1.39	26.20	32.23	1.49	29.40	36.16	14.40	21.76
120	1.21	20.80	1.19	27.20	33.46	1.38	33.00	40.59	1.47	36.80	45.26	28.80	16.46
240	1.45	26.50	1.18	34.50	42.44	1.37	41.50	51.05	1.46	46.10	56.70	57.60	0.00
360	1.60	30.60	1.18	39.70	48.83	1.36	47.50	58.43	1.44	52.60	64.70	86.40	0.00
600	1.79	36.40	1.17	47.20	58.06	1.35	56.10	69.00	1.42	61.90	76.14	144.00	0.00
1440	2.24	39.20	1.17	63.70	78.35	1.34	75.10	92.37	1.42	82.40	101.35	345.60	0.00

* Z2 is a growth factor from M5 rainfalls

REQUIRED STORAGE VOLUME PER RAINFALL DURATION FOR DISCHARGE RATE v₂

rainfall duration [min]	rainfall factor Z1	M5-D rainfalls [mm]	M10-D			M30-D			M100-D			outflow from attenuation tank [m ³]	required storage [m ³]
			Z2	rainfalls [mm]	inflow [m ³]	Z2	rainfalls [mm]	inflow [m ³]	Z2	rainfalls [mm]	inflow [m ³]		
5	0.37	6.10	1.17	8.20	10.09	1.45	11.40	14.02	1.88	16.30	20.05	1.20	18.85
10	0.52	8.40	1.18	11.40	14.02	1.47	15.90	19.56	1.93	22.70	27.92	2.40	25.52
15	0.63	9.90	1.19	13.40	16.48	1.49	18.70	23.00	1.97	26.70	32.84	3.60	29.24
30	0.80	12.70	1.20	17.00	20.91	1.49	23.50	28.91	1.98	33.00	40.59	7.20	33.39
60	1.00	16.20	1.20	21.50	26.45	1.49	29.40	36.16	1.97	40.80	50.18	14.40	35.78
120	1.21	20.80	1.19	27.20	33.46	1.47	36.80	45.26	1.92	50.40	61.99	28.80	33.19
240	1.45	26.50	1.18	34.50	42.44	1.46	46.10	56.70	1.88	62.40	76.75	57.60	19.15
360	1.60	30.60	1.18	39.70	48.83	1.44	52.60	64.70	1.85	70.60	86.84	86.40	0.44
600	1.79	36.40	1.17	47.20	58.06	1.42	61.90	76.14	1.80	82.40	101.35	144.00	0.00
1440	2.24	39.20	1.17	63.70	78.35	1.42	82.40	101.35	1.78	107.90	132.72	345.60	0.00

* Z2 is a growth factor from M5 rainfalls

Met Eireann

Return Period Rainfall Depths for sliding Durations
 Irish Grid: Easting: 213664, Northing: 311443,

DURATION	Interval 6months, 1year, 5 mins 10 mins 15 mins 30 mins 1 hour 2 hours 3 hours 4 hours 6 hours 9 hours 12 hours 18 hours 24 hours	Years													
		2,	3,	4,	5,	10,	20,	30,	50,	75,	100,	150,	200,	250,	500,
5 mins	2.6,	4.3,	5.3,	5.9,	6.5,	8.2,	10.1,	11.4,	13.3,	15.0,	16.3,	18.3,	19.9,	21.2,	N/A
10 mins	3.6,	6.0,	7.4,	8.3,	9.0,	11.4,	14.1,	15.9,	18.5,	20.9,	22.7,	25.5,	27.7,	29.6,	N/A
15 mins	4.2,	7.1,	8.7,	9.7,	10.6,	13.4,	16.6,	18.7,	21.8,	24.5,	26.7,	30.0,	32.6,	34.8,	N/A
30 mins	5.5,	9.2,	11.2,	12.5,	13.5,	17.0,	20.9,	23.5,	27.1,	30.4,	33.0,	37.0,	40.1,	42.6,	N/A
1 hour	7.3,	11.9,	14.4,	16.0,	17.3,	21.5,	26.2,	29.4,	33.8,	37.7,	40.8,	45.5,	49.2,	52.2,	N/A
2 hours	9.7,	15.5,	18.5,	20.5,	22.1,	27.2,	33.0,	36.8,	42.1,	46.8,	50.4,	56.0,	60.4,	63.9,	N/A
3 hours	11.4,	18.0,	21.5,	23.7,	25.5,	31.3,	37.7,	42.0,	47.9,	53.1,	57.1,	63.3,	68.1,	72.0,	N/A
4 hours	12.8,	20.1,	23.8,	26.3,	28.3,	34.5,	41.5,	46.1,	52.4,	58.1,	62.4,	69.0,	74.1,	78.3,	N/A
6 hours	15.0,	23.4,	27.6,	30.4,	32.6,	39.7,	47.5,	52.6,	59.6,	65.8,	70.6,	77.9,	83.5,	88.2,	N/A
9 hours	17.7,	27.2,	32.0,	35.2,	37.7,	45.6,	54.3,	59.9,	67.8,	74.7,	79.9,	88.0,	94.2,	99.2,	N/A
12 hours	19.9,	30.3,	35.6,	39.0,	41.7,	50.3,	59.7,	65.8,	74.3,	81.6,	87.3,	95.9,	102.5,	107.9,	N/A
18 hours	23.4,	35.3,	41.2,	45.1,	48.2,	57.7,	68.3,	75.1,	84.4,	92.6,	98.8,	108.3,	115.6,	121.5,	N/A
24 hours	26.3,	39.3,	45.8,	50.1,	53.3,	63.7,	75.1,	82.4,	92.5,	101.2,	107.9,	118.1,	125.8,	132.2,	154.0,
2 days	34.6,	49.3,	56.4,	61.0,	64.5,	75.5,	87.2,	94.7,	104.8,	113.5,	120.1,	130.0,	137.5,	143.6,	164.4,
3 days	41.7,	57.8,	65.5,	70.4,	74.1,	85.6,	97.9,	105.6,	115.9,	124.8,	131.4,	141.4,	148.9,	155.0,	175.5,
4 days	48.2,	65.6,	73.7,	78.9,	82.8,	94.8,	107.5,	115.4,	126.1,	135.1,	141.9,	151.9,	159.5,	165.6,	186.1,
6 days	60.2,	79.7,	88.6,	94.2,	98.4,	111.4,	124.9,	133.2,	144.3,	153.7,	160.7,	171.0,	178.8,	185.0,	205.7,
8 days	71.4,	92.6,	102.2,	108.2,	112.7,	126.5,	140.6,	149.3,	160.9,	170.5,	177.7,	188.4,	196.2,	202.6,	223.6,
10 days	82.0,	104.8,	114.9,	121.3,	126.1,	140.5,	155.2,	164.3,	176.2,	186.2,	193.5,	204.4,	212.5,	218.9,	240.2,
12 days	92.3,	116.4,	127.1,	133.8,	138.8,	153.8,	169.1,	178.4,	190.7,	200.9,	208.4,	219.5,	227.7,	234.3,	255.9,
16 days	112.1,	138.7,	150.3,	157.5,	162.9,	178.9,	195.1,	204.9,	217.8,	228.4,	236.3,	247.7,	256.2,	263.0,	285.0,
20 days	131.3,	159.9,	172.3,	180.0,	185.7,	202.6,	219.6,	229.8,	243.1,	254.2,	262.2,	274.0,	282.7,	289.6,	312.1,
25 days	154.7,	185.6,	198.8,	207.0,	213.0,	230.8,	248.6,	259.3,	273.1,	284.5,	292.9,	305.0,	313.9,	320.9,	343.9,

NOTES:

N/A Data not available

These values are derived from a Depth Duration Frequency (DDF) Model

For details refer to:

'Fitzgerald D. L. (2007), Estimates of Point Rainfall Frequencies, Technical Note No. 61, Met Eireann, Dublin',
 Available for download at www.met.ie/climate/dataproducts/Estimation-of-Point-Rainfall-Frequencies_TN61.pdf

Technical Specification

Control Point	Head (m)	Flow (l/s)
Primary Design	0.727	4.000
Flush-Flo™	0.217	3.997
Kick-Flo®	0.488	3.328
Mean Flow		3.439

Hydro-Brake® Optimum Flow Control including:

- 3 mm grade 304L stainless steel
- Integral stainless steel pivoting by-pass door allowing clear line of sight through to outlet, c/w stainless steel operating rope
- Beed blasted finish to maximise corrosion resistance
- Stainless steel fixings
- Rubber gasket to seal outlet



hydro-int.com/patents

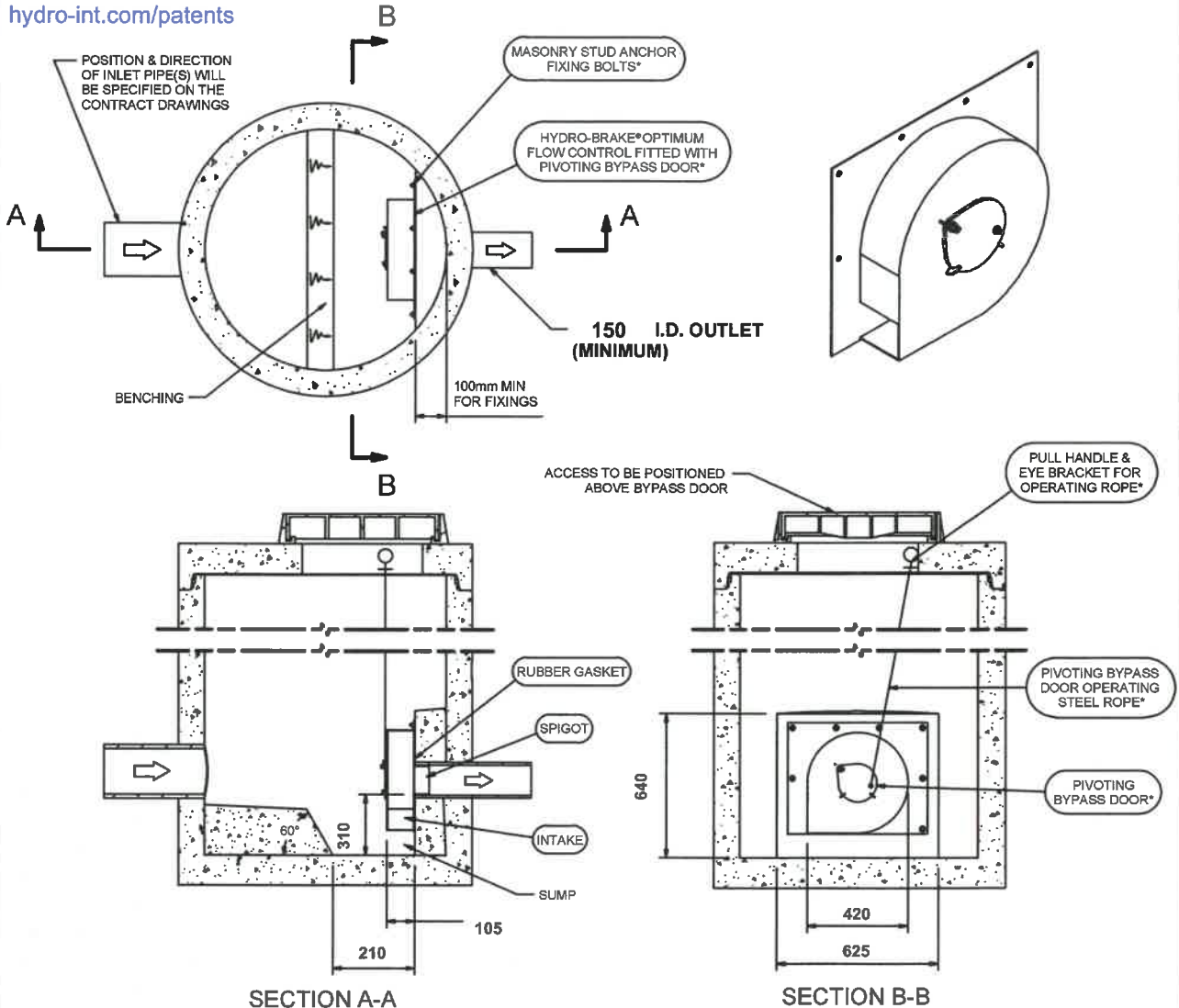

IMPORTANT: LIMIT OF HYDRO INTERNATIONAL SUPPLY
 THE DEVICE WILL BE HANDED TO SUIT SITE CONDITIONS
 FOR SITE SPECIFIC DETAILS AND MINIMUM CHAMBER SIZE REFER TO HYDRO INTERNATIONAL
 ALL CIVIL AND INSTALLATION WORK BY OTHERS
 * WHERE SUPPLIED
 HYDRO-BRAKE® FLOW CONTROL & HYDRO-BRAKE® OPTIMUM FLOW CONTROL ARE REGISTERED TRADEMARKS FOR FLOW
 CONTROLS DESIGNED AND MANUFACTURED EXCLUSIVELY BY HYDRO INTERNATIONAL

THIS DESIGN LAYOUT IS FOR ILLUSTRATIVE PURPOSES ONLY. NOT TO SCALE.

DESIGN ADVICE



The head/flow characteristics of this SHE-0099-4000-0727-4000 Hydro-Brake® Optimum Flow Control are unique. Dynamic hydraulic modelling evaluates the full head/flow characteristic curve.
The use of any other flow control will invalidate any design based on this data and could constitute a flood risk.

Hydro
International

DATE 7/14/2020 10:48 AM

SITE Ballinamore

DESIGNER Marc McBride

REF 20.051

SHE-0099-4000-0727-4000

Hydro-Brake® Optimum

Technical Specification

Control Point	Head (m)	Flow (l/s)
Primary Design	0.727	4.000
Flush-Flo	0.217	3.997
Kick-Flo®	0.488	3.328
Mean Flow		3.439



PT/329/0412

hydro-int.com/patents

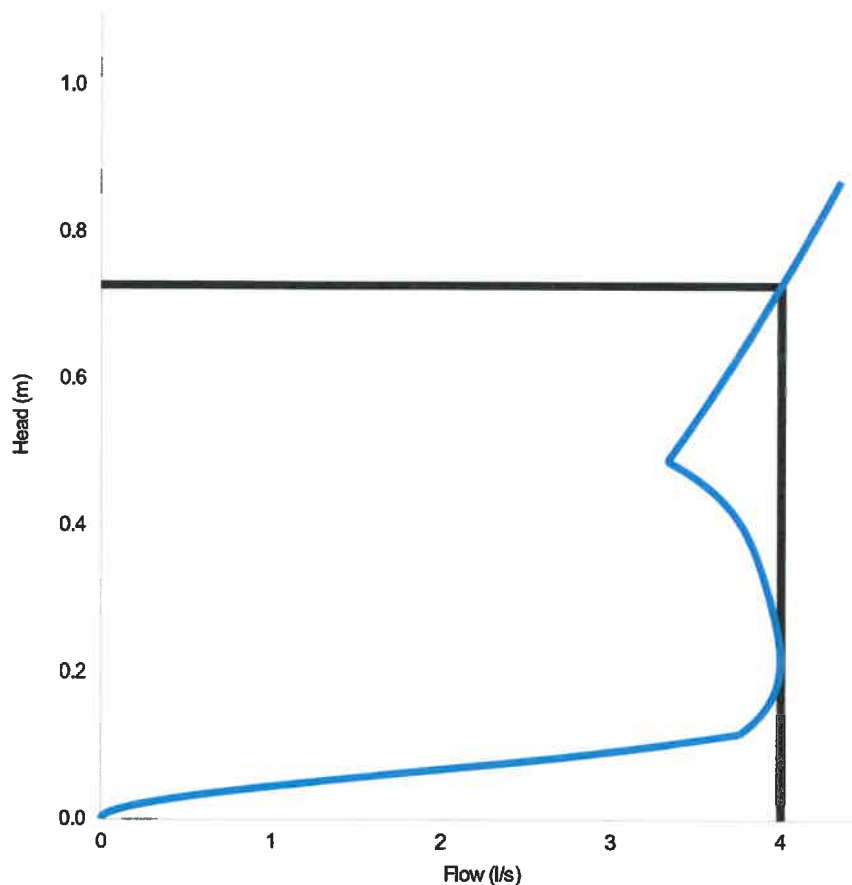

Head (m)	Flow (l/s)
0.000	0.000
0.025	0.336
0.050	1.200
0.075	2.308
0.100	3.255
0.125	3.802
0.150	3.907
0.175	3.966
0.201	3.993
0.226	3.996
0.251	3.984
0.276	3.962
0.301	3.934
0.326	3.903
0.351	3.867
0.376	3.823
0.401	3.766
0.426	3.687
0.451	3.577
0.476	3.422
0.501	3.371
0.526	3.447
0.552	3.521
0.577	3.593
0.602	3.664
0.627	3.733
0.652	3.801
0.677	3.867
0.702	3.933
0.727	3.997

DESIGN ADVICE

The head/flow characteristics of this SHE-0099-4000-0727-4000 Hydro-Brake Optimum® Flow Control are unique. Dynamic hydraulic modelling evaluates the full head/flow characteristic curve.



The use of any other flow control will invalidate any design based on this data and could constitute a flood risk.



SHE-0099-4000-0727-4000

Hydro-Brake Optimum®

DATE 14/07/2020 10:48

Site Ballinamore

DESIGNER Marc McBride

Ref 20.051

SEPARATORS

A RANGE OF FUEL/OIL SEPARATORS
FOR PEACE OF MIND



Klargester.

60 YEARS OF
Expertise &
1955-2015 Innovation



Separators

A RANGE OF FUEL/OIL SEPARATORS FOR PEACE OF MIND

Surface water drains normally discharge to a watercourse or indirectly into underground waters (groundwater) via a soakaway. Contamination of surface water by oil, chemicals or suspended solids can cause these discharges to have a serious impact on the receiving water.

The Environment Regulators, Environment Agency, England and Wales, SEPA, Scottish Environmental Protection Agency in Scotland and Department of Environment & Heritage in Northern Ireland, have published guidance on surface water disposal, which offers a range of means of dealing with pollution both at source and at the point of discharge from site (so called 'end of pipe' treatment). These techniques are known as 'Sustainable Drainage Systems' (SuDS).

Where run-off is draining from relatively low risk areas such as car-parks and non-operational areas, a source control approach, such as permeable surfaces or infiltration trenches, may offer a suitable means of treatment, removing the need for a separator.

Oil separators are installed on surface water drainage systems to protect receiving waters from pollution by oil, which may be present due to minor leaks from vehicles and plant, from accidental spillage.

Effluent from industrial processes and vehicle washing should normally be discharged to the foul sewer (subject to the approval of the sewerage undertaker) for further treatment at a municipal treatment works.

SEPARATOR STANDARDS AND TYPES

A British (and European) standard (EN 858-1 and 858-2) for the design and use of prefabricated oil separators has been adopted. New prefabricated separators should comply with the standard.

SEPARATOR CLASSES

The standard refers to two 'classes' of separator, based on performance under standard test conditions.

CLASS I

Designed to achieve a concentration of less than 5mg/l of oil under standard test conditions, should be used when the separator is required to remove very small oil droplets.

CLASS II

Designed to achieve a concentration of less than 100mg/l oil under standard test conditions and are suitable for dealing with discharges where a lower quality requirement applies (for example where the effluent passes to foul sewer).

Both classes can be produced as full retention separators. The oil concentration limits of 5 mg/l and 100 mg/l are only applicable under standard test conditions. It should not be expected that separators will comply with these limits when operating under field conditions.

FULL RETENTION SEPARATORS

Full retention separators treat the full flow that can be delivered by the drainage system, which is normally equivalent to the flow generated by a rainfall intensity of 65mm/hr.

On large sites, some short term flooding may be an acceptable means of limiting the flow rate and hence the size of full retention systems.

Get in touch for a **FREE** professional site visit and a representative will contact you within 5 working days to arrange a visit.
helpingyou@klargester.com to make the right decision or call **028 302 66799**

BYPASS SEPARATORS

Bypass separators fully treat all flows generated by rainfall rates of up to 6.5mm/hr. This covers over 99% of all rainfall events. Flows above this rate are allowed to bypass the separator. These separators are used when it is considered an acceptable risk not to provide full treatment for high flows, for example where the risk of a large spillage and heavy rainfall occurring at the same time is small.

FORECOURT SEPARATORS

Forecourt separators are full retention separators specified to retain on site the maximum spillage likely to occur on a petrol filling station. They are required for both safety and environmental reasons and will treat spillages occurring during vehicle refuelling and road tanker delivery. The size of the separator is increased in order to retain the possible loss of the contents of one compartment of a road tanker, which may be up to 7,600 litres.

SELECTING THE RIGHT SEPARATOR

The chart on the following page gives guidance to aid selection of the appropriate type of fuel/oil separator for use in surface water drainage systems which discharge into rivers and soakaways.

For further detailed information, please consult the Environment Agency Pollution Prevention Guideline 03 (PPG 3) 'Use and design of oil separators in surface water drainage systems' available from their website.

Kingspan Klargester has a specialist team who provide technical assistance in selecting the appropriate separator for your application.

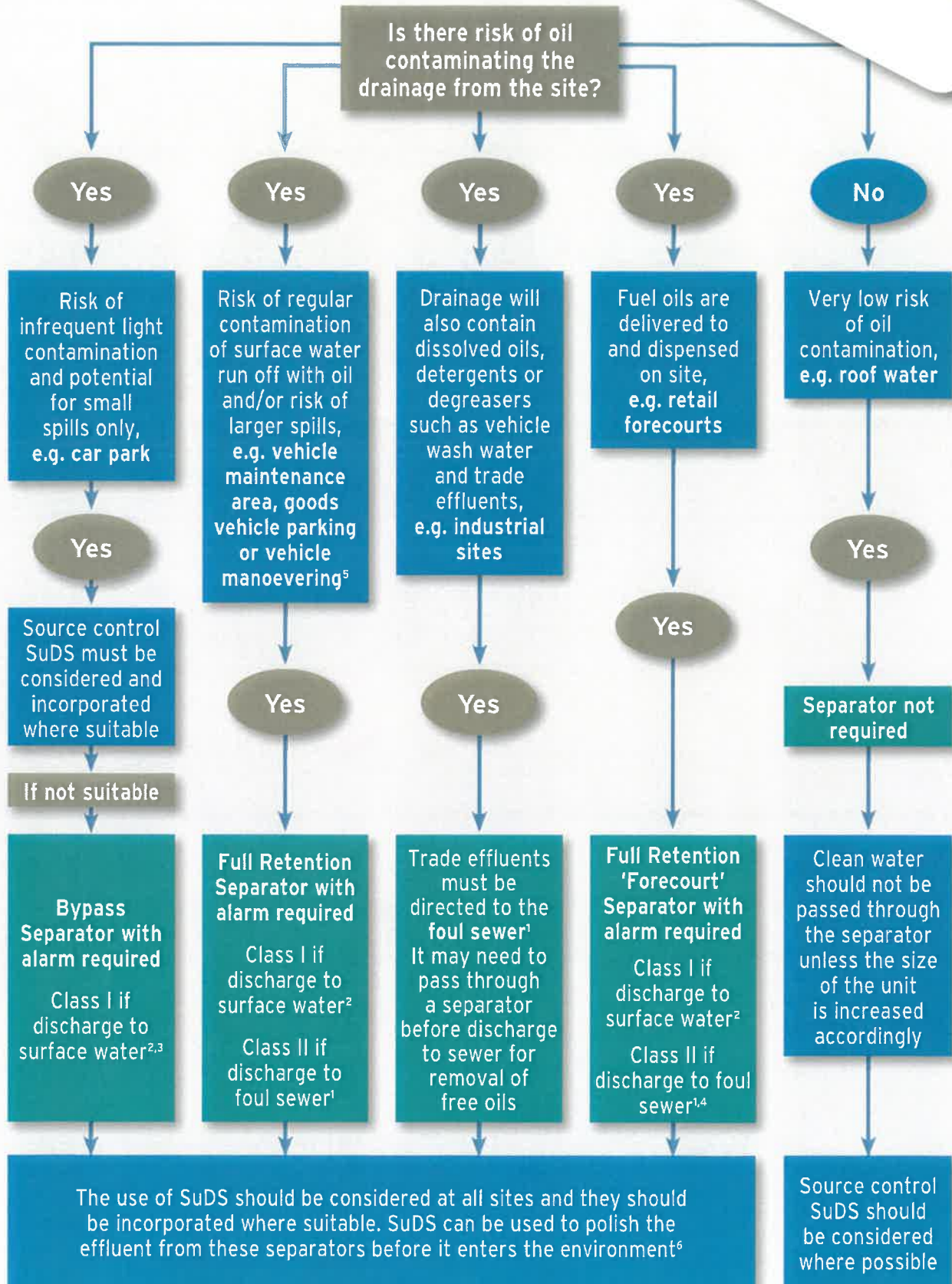

1 You must seek prior permission from your local sewer provider before you decide which separator to install and before you make any discharge.
 2 You must seek prior permission from the relevant environmental body before you decide which separator to install.
 3 In this case, if it is considered that there is a low risk of pollution a source control SuDS scheme may be appropriate.
 4 In certain circumstances, the sewer provider may require a Class 1 separator for discharges to sewer to prevent explosive atmospheres from being generated.
 5 Drainage from higher risk areas such as vehicle maintenance yards and goods vehicle parking areas should be connected to foul sewer in preference to surface water.
 6 In certain circumstances, a separator may be one of the devices used in the SuDS scheme. Ask us for advice.

Bypass NSB RANGE

APPLICATION

Bypass separators are used when it is considered an acceptable risk not to provide full treatment, for very high flows, and are used, for example, where the risk of a large spillage and heavy rainfall occurring at the same time is small, e.g.

- Surface car parks.
- Roadways.
- Lightly contaminated commercial areas.

PERFORMANCE

Klargester were one of the first UK manufacturers to have separators tested to EN 858-1. Klargester have now added the NSB bypass range to their portfolio of certified and tested models. The NSB number denotes the maximum flow at which the separator treats liquids. The British Standards Institute (BSI) tested the required range of Kingspan Klargester Bypass separators and certified their performance in relation to their flow and process performance assessing the effluent qualities to the requirements of EN 858-1. Klargester bypass separator designs follow the parameters determined during the testing of the required range of bypass separators.

Each bypass separator design includes the necessary volume requirements for:

- Oil separation capacity.
- Oil storage volume.
- Silt storage capacity.
- Coalescer.

The unit is designed to treat 10% of peak flow. The calculated drainage areas served by each separator are indicated according to the formula given by PPG3 $NSB = 0.0018A(m^2)$. Flows generated by higher rainfall rates will pass through part of the separator and bypass the main separation chamber.

Class I separators are designed to achieve a concentration of 5mg/litre of oil under standard test conditions.

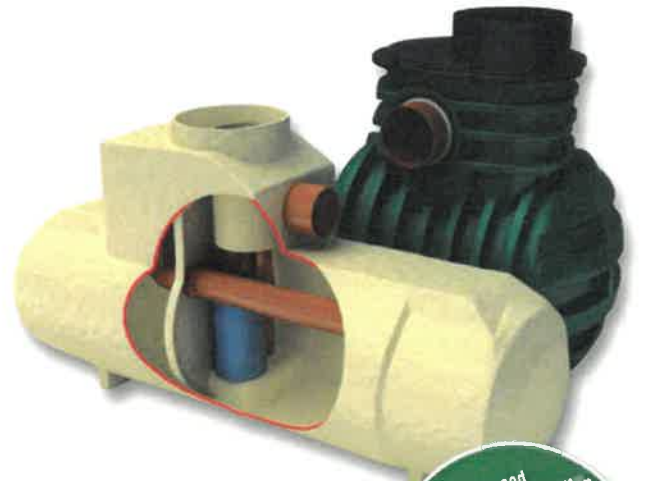

FEATURES

- Light and easy to install.
- Inclusive of silt storage volume.
- Fitted inlet/outlet connectors.
- Vent points within necks.
- Oil alarm system available (required by EN 858-1 and PPG3).
- Extension access shafts for deep inverts.
- Maintenance from ground level.
- GRP or rotomoulded construction (subject to model).

To specify a nominal size bypass separator, the following information is needed:-

- The calculated flow rate for the drainage area served. Our designs are based on the assumption that any interconnecting pipework fitted elsewhere on site does not impede flow into or out of the separator and that the flow is not pumped.
- The drain invert inlet depth.
- Pipework type, size and orientation.

SIZES AND SPECIFICATIONS

UNIT NOMINAL SIZE	FLOW (l/s)	PEAK FLOW RATE (l/s)	DRAINAGE AREA (m ²)	STORAGE CAPACITY (litres)		UNIT LENGTH (mm)	UNIT DIA. (mm)	ACCESS SHAFT DIA. (mm)	BASE TO INLET INVERT (mm)	BASE TO OUTLET INVERT (mm)	STANDARD FALL ACROSS (mm)	MIN. INLET INVERT (mm)	STANDARD PIPEWORK DIA.
				SILT	OIL								
NSBP003	3	30	1670	300	45	1700	1350	600	1420	1320	100	500	160
NSBP004	4.5	45	2500	450	60	1700	1350	600	1420	1320	100	500	160
NSBP006	6	60	3335	600	90	1700	1350	600	1420	1320	100	500	160
NSBE010	10	100	5560	1000	150	2069	1220	750	1450	1350	100	700	315
NSBE015	15	150	8335	1500	225	2947	1220	750	1450	1350	100	700	315
NSBE020	20	200	11111	2000	300	3893	1220	750	1450	1350	100	700	375
NSBE025	25	250	13890	2500	375	3575	1420	750	1680	1580	100	700	375
NSBE030	30	300	16670	3000	450	4265	1420	750	1680	1580	100	700	450
NSBE040	40	400	22222	4000	600	3230	1920	600	2185	2035	150	1000	500
NSBE050	50	500	27778	5000	750	3960	1920	600	2185	2035	150	1000	600
NSBE075	75	750	41667	7500	1125	5841	1920	600	2235	2035	200	950	675
NSBE100	100	1000	55556	10000	1500	7661	1920	600	2235	2035	200	950	750
NSBE125	125	1250	69444	12500	1875	9548	1920	600	2235	2035	200	950	750

■ Rotomoulded chamber construction ■ GRP chamber construction * Some units have more than one access shaft – diameter of largest shown.

Full Retention NSF RANGE



APPLICATION

Full retention separators are used in high risk spillage areas such as:

- Fuel distribution depots.
- Vehicle workshops.
- Scrap Yards

PERFORMANCE

Kingspan Klargestar were the first UK manufacturer to have the required range (3-30 l/sec) certified to EN 858-1 in the UK. The NSF number denotes the flow at which the separator operates.

The British Standards Institute (BSI) have witnessed the performance tests of the required range of separators and have certified their performance, in relation to their flow and process performance to ensure that they met the effluent quality requirements of EN 858-1. Larger separator designs have been determined using the formulas extrapolated from the test range.

Each full retention separator design includes the necessary volume requirements for:

- Oil separation capacity.
- Oil storage volume.
- Silt storage capacity.
- Coalescer (Class I units only).
- Automatic closure device.

Klargester full retention separators treat the whole of the specified flow.

FEATURES

- Light and easy to install.
- Class I and Class II designs.
- 3-30 l/sec range independently tested and performance sampled, certified by the BSI.
- Inclusive of silt storage volume.
- Fitted inlet/outlet connectors.

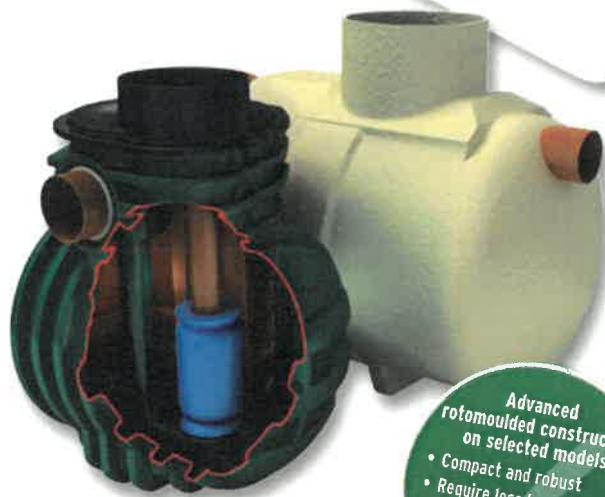

Advanced rotomoulded construction on selected models

- Compact and robust
- Require less backfill
- Tough, lightweight and easy to handle

- Oil alarm system available.
- Vent points within necks.
- Extension access shafts for deep inverts.
- Maintenance from ground level.
- GRP or rotomoulded construction (subject to model).

To specify a nominal size full retention separator, the following information is needed:-

- The calculated flow rate for the drainage area served. Our designs are based on the assumption that any interconnecting pipework fitted elsewhere on site does not impede flow into or out of the separator and that the influent is not pumped.
- The required discharge standard. This will decide whether a Class I or Class II unit is required.
- The drain invert inlet depth.
- Pipework type, size and orientation.

SIZES AND SPECIFICATIONS

UNIT NOMINAL SIZE	FLOW (l/s)	DRAINAGE AREA (m ²) PPG-3 (0.018)	STORAGE CAPACITY (litres)		UNIT LENGTH (mm)	UNIT DIA. (mm)	BASE TO INLET INVERT (mm)	BASE TO OUTLET INVERT	MIN. INLET INLET (mm)	STANDARD PIPEWORK DIA. (mm)
			SILT	OIL						
NSFP003	3	170	300	30	1700	1350	1420	1345	500	160
NSFP006	6	335	600	60	1700	1350	1420	1345	500	160
NSFA010	10	555	1000	100	2610	1225	1050	1000	500	200
NSFA015	15	835	1500	150	3910	1225	1050	1000	500	200
NSFA020	20	1115	2000	200	3200	2010	1810	1760	1000	315
NSFA030	30	1670	3000	300	3915	2010	1810	1760	1000	315
NSFA040	40	2225	4000	400	4640	2010	1810	1760	1000	315
NSFA050	50	2780	5000	500	5425	2010	1810	1760	1000	315
NSFA065	65	3610	6500	650	6850	2010	1810	1760	1000	315
NSFA080	80	4445	8000	800	5744	2820	2500	2450	1000	300
NSFA100	100	5560	10000	1000	6200	2820	2500	2450	1000	400
NSFA125	125	6945	12500	1250	7365	2820	2500	2450	1000	450
NSFA150	150	8335	15000	1500	8675	2820	2550	2450	1000	525
NSFA175	175	9725	17500	1750	9975	2820	2550	2450	1000	525
NSFA200	200	11110	20000	2000	11280	2820	2550	2450	1000	600

■ Rotomoulded chamber construction ■ GRP chamber construction

Washdown & Silt

APPLICATION

This unit can be used in areas such as car wash and other cleaning facilities that discharge directly into a foul drain, which feeds to a municipal treatment facility.

If emulsifiers are present the discharge must not be allowed to enter an NS Class I or Class II unit.

- Car wash.
- Tool hire depots.
- Truck cleansing.
- Construction compounds cleansing points.

PERFORMANCE

Such wash down facilities must not be allowed to discharge directly into surface water but must be directed to a foul connection leading to a municipal treatment works as they utilise emulsifiers, soaps and detergents, which can dissolve and disperse the oils.

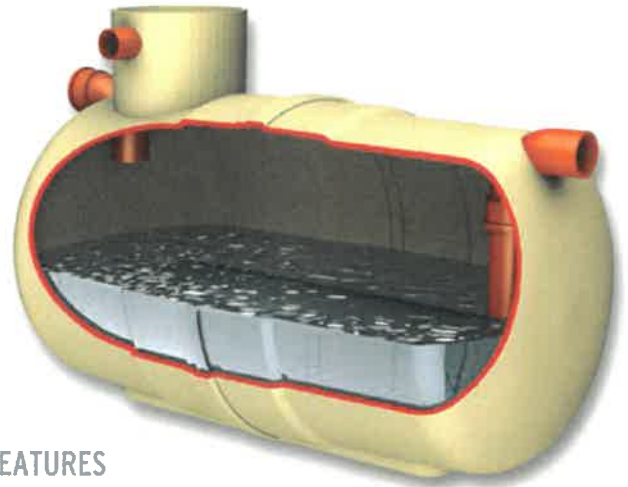

FEATURES

- Light and easy to install.
- Inclusive of silt storage volume.
- Fitted inlet/outlet connectors.
- Vent points within necks.
- Extension access shafts for deep inverts.
- Maintenance from ground level.

SIZES AND SPECIFICATIONS

REF.	TOTAL CAPACITY (litres)	MAX. REC. SILT	MAX. FLOW RATE (l/s)	LENGTH (mm)	DIAMETER (mm)	ACCESS SHAFT DIA. (mm)	BASE TO INLET INVERT (mm)	BASE TO OUTLET INVERT (mm)	STANDARD FALL ACROSS UNIT (mm)	MIN. INLET INVERT (mm)	STANDARD PIPEWORK DIA. (mm)	APPROX EMPTY (kg)
WI/010	1000	500	3	1123	1225	460	1150	1100	50	500	160	60
WI/020	2000	1000	5	2074	1225	460	1150	1100	50	500	160	120
WI/030	3000	1500	8	2952	1225	460	1150	1100	50	500	160	150
WI/040	4000	2000	11	3898	1225	460	1150	1100	50	500	160	180
WI/060	6000	3000	16	4530	1440	600	1360	1310	50	500	160	320
WI/080	8000	4000	22	3200	2020	600	2005	1955	50	500	160	585
WI/100	10000	5000	27	3915	2020	600	2005	1955	50	500	160	680
WI/120	12000	6000	33	4640	2020	600	2005	1955	50	500	160	770
WI/150	15000	7500	41	5435	2075	600	1940	1890	50	500	160	965
WI/190	19000	9500	52	6865	2075	600	1940	1890	50	500	160	1200

Car Wash Silt Trap

APPLICATION

Car Wash silt trap is designed for use before a separator in car wash applications to ensure effective silt removal.

FEATURES

- FACTA Class B covers.
- Light and easy to install.
- Maintenance from ground level.



Forecourt



APPLICATION

The forecourt separator is designed for installation in petrol filling station forecourts and similar applications. The function of the separator is to intercept hydrocarbon pollutants such as petroleum and oil and prevent their entry to the drainage system, thus protecting the environment against hydrocarbon contaminated surface water run-off and gross spillage.

PERFORMANCE

Operation ensures that the flow cannot exit the unit without first passing through the coalescer assembly.

In normal operation, the forecourt separator has sufficient capacity to provide storage for separated pollutants within the main chamber, but is also able to contain up to 7,600 litres of pollutant arising from the spillage of a fuel delivery tanker compartment on the petrol forecourt. The separator has been designed to ensure that oil cannot exit the separator in the event of a major spillage, subsequently the separator should be emptied immediately.

FEATURES

- Light and easy to install.
- Inclusive of silt storage volume.
- Fitted inlet/outlet connectors.
- Vent points within necks.
- Extension access shafts for deep inverts.
- Maintenance from ground level.

SIZES AND SPECIFICATIONS

ENVIRORECEPTOR CLASS	TOTAL CAP. (litres)	DRAINAGE AREA (m ²)	MAX. FLOW RATE (l/s)	LENGTH (mm)	DIAMETER (mm)	ACCESS SHAFT DIA. (mm)	BASE TO INLET INVERT (mm)	BASE TO OUTLET INVERT (mm)	STD. FALL ACROSS UNIT (mm)	MIN. INLET INVERT (mm)	STD. PIPEWORK (mm)	EMPTY WEIGHT (kg)
I	10000	555	10	3963	1920	600	2110	2060	50	400	160	500
II	10000	555	10	3963	1920	600	2110	2060	50	400	160	500
I	10000	1110	20	3963	1920	600	2110	2060	50	400	200	500
II	10000	1110	20	3963	1920	600	2110	2060	50	400	200	500



- Class I and Class II design.
- Oil storage volume.
- Coalescer (Class I unit only).
- Automatic closure device.
- Oil alarm system available.

INSTALLATION

The unit should be installed on a suitable concrete base slab and surrounded with concrete or pea gravel backfill. See sales drawing for installation.

If the separator is to be installed within a trafficked area, then a suitable cover slab must be designed to ensure that loads are not transmitted to the unit.

The separator should be installed and vented in accordance with Health and Safety Guidance Note HS(G)41 for filling stations, subject to Local Authority requirements.

Alarm Systems

British European Standard EN 858-1 and Environment Agency Pollution Prevention Guideline PPG3 requires that all separators are to be fitted with an oil level alarm system and that it should be installed and calibrated by a suitably qualified technician so that it will respond to an alarm condition when the separator requires emptying.

- Easily fitted to existing tanks.
- Excellent operational range.
- Visual and audible alarm.
- Additional telemetry option.



PROFESSIONAL INSTALLERS

Kingspan Klargester Accredited Installers

Experience shows that correct installation is a prerequisite for the long-lasting and successful operation of any wastewater treatment product. This is why using an installer with the experience and expertise to install your product is highly recommended.



Services include :

- Site survey to establish ground conditions and soil types
- Advice on system design and product selection
- Assistance on gaining environmental consents and building approvals
- Tank and drainage system installation
- Connection to discharge point and electrical networks
- Waste emptying and disposal

Discover more about the Accredited Installers and locate your local expert online.

www.kingspanenviro.com/klargester



CARE & MAINTENANCE

Kingspan Environmental Services

Who better to look after your treatment plant than the people who designed and built it?



Kingspan Environmental have a dedicated service division providing maintenance for wastewater products.

Factory trained engineers are available for site visits as part of a planned maintenance contract or on a one-off call out basis.

To find out more about protecting your investment and ensuring peace of mind, call us on:

0844 846 0500

or visit us online:

www.kingspanenvservice.com



COMMERCIAL WASTEWATER SOLUTIONS

- **BIODISC® & ENVIROSAFE**
HIGH PERFORMANCE SEWAGE TREATMENT SYSTEMS
- **PACKAGE PUMP STATIONS**
- **PUMPSTOR24 PUMPING SYSTEMS**
- **OIL/WATER SEPARATORS**
- **BELOW GROUND STORAGE TANKS**
- **GREASE & SILT TRAPS**

RAINWATER SOLUTIONS

- **BELOW GROUND RAINWATER HARVESTING SYSTEMS**
- **ABOVE GROUND RAINWATER HARVESTING SYSTEMS**

Klargester

UK: College Road North, Aston Clinton, Aylesbury, Buckinghamshire HP22 5EW

Tel: +44 (0) 1296 633000 Fax: +44 (0) 1296 633001 Scottish Office: Tel: +44 (0) 1355 248484
email: klargester@kingspan.com

Ireland: Unit 1a, Derryboy Road, Cambane Business Park, Newry, Co. Down BT35 6QH

NI Tel : +44 (0) 28 302 66799 Fax: +44 (0) 28 302 60046 ROI Tel: 048 302 66799 Fax: 048 302 60046
email: klargesterinfor@kingspan.com

Visit our website www.kingspanenviro.com/klargester



In keeping with Company policy of continuing research and development and in order to offer our clients the most advanced products, Kingspan Environmental reserves the right to alter specifications and drawings without prior notice.

Issue No. 21: September 2015



Modular Geo-Void Systems

Total Water Management

ESS EcoCell

Ecological Tank Systems

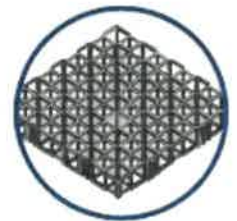
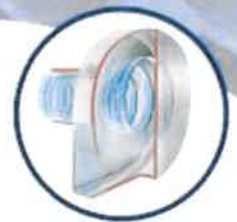
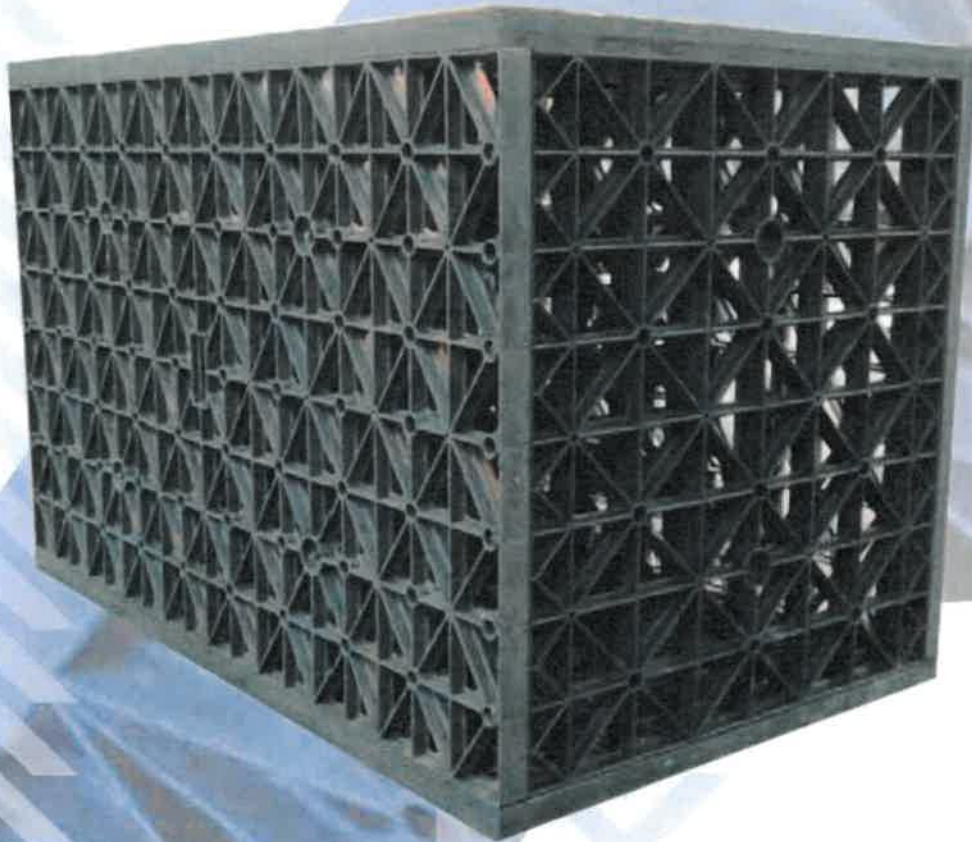

ENVIRONMENTAL SUSTAINABLE SOLUTIONS LTD

Environmental Sustainable Solutions

Welcome to Environmental Sustainable Solutions; specialist suppliers and designers of geocomposites and water re-use systems. Environmental Sustainable Solutions can help you achieve innovative results for all your requirements:-

- Ⓞ Stormwater Management
- Ⓞ Gas Barrier Protection
- Ⓞ Stormwater Attenuation
- Ⓞ Contaminated Land Development
- Ⓞ Stormwater Drainage
- Ⓞ Ground Stabilisation
- Ⓞ Rainwater Recycling Management
- Ⓞ Structural Waterproofing
- Ⓞ Gas Venting Systems
- Ⓞ Damp-proofing projects

Over the last 12 years Environmental Sustainable Solutions, and associated companies, have designed and installed thousands of water recycling, drainage and attenuation tank systems for schools, car parks, retail parks, offices and sports arenas throughout Ireland, UK, Europe and the Middle East.

Our wide range of environmental protection products, surface water drainage modules and modular water storage tank systems provides maximum design flexibility for engineers and architects working on even the most demanding of storm water storage and recycling projects.

Stormwater Management And Design

Stormwater is the phrase used to describe the excess rainwater that flows from rooftops, roads, car parks and other buildings. This water can contain many pollutants picked up from roofs and highways. In extreme weather conditions sudden heavy downpours of rain can cause major environmental disasters. Using our Rainmanager products; stormwater can not only safely be removed, but it can be stored and recycled for commercial and domestic use.

How it works

- ESS Attenuation Tank

Stormwater enters the attenuation tank via the inlet manhole, which incorporates a silt collection sump and a galvanised leaf collection basket. Water passes through the tank and exits through the outlet manhole, which contains an AquaBrake flow control device.

This flow control device regulates the release rate of water from the tank, and in so doing, enables the tank to fill. As a result of water entering the tank at a greater rate than it can exit, the void space then fills with water. While the tank fills, air is vented from the tank.

The Inlet/Outlet pipe will act as a flushing channel. This perforated pipe is wrapped completely in High Flow Filtering Geotextile, which prevents silt entering the block area. As the tank continues to empty at a pre-determined rate, air re-enters the tank via the same air vent system. The roof of the completed tank must be lower than the lowest gully trap on site.

Benefits

- Ⓞ 100% sealed tank
- Ⓞ Full installation service provided
- Ⓞ 12 years experience as market leader
- Ⓞ Quick installation – reduce site access delays
- Ⓞ Increased land usage – tanks are sub surface
- Ⓞ Economical – generally more cost efficient than any other equivalent sealed tank
- Ⓞ Cost effective – reduced costs for excavation and disposal of material
- Ⓞ Modular – easy to create any shape
- Ⓞ Strong – designed to support shear loading
- Ⓞ Lightweight – no cranes required
- Ⓞ Determinate volume – one cubic metre of matrix tank modules contain 950 litres of water, whereas stone fill will only provide 300 litres of storage per cubic metre.

Soakaway

The soakaway is normally best built as a long narrow structure.

The inlet pipe comes in at roof level and faces downwards so that the water can percolate into the tank.

The blocks are wrapped in Geotextile, to protect them and also to keep clay from filling up the void.

An air vent pipe is installed on the highest point with a cowl on top or vented back to an inlet manhole.

There is no outlet from a soakaway, therefore no flow control unit is required.

Protecting the Environment

Stormwater Storage Tank

SUITABLE FOR USE UNDER:

- Roadways
- Car parks
- Green areas

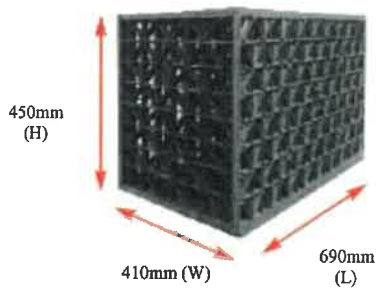

Single
8 Modules/m³
Flowrate - 2300 I/min

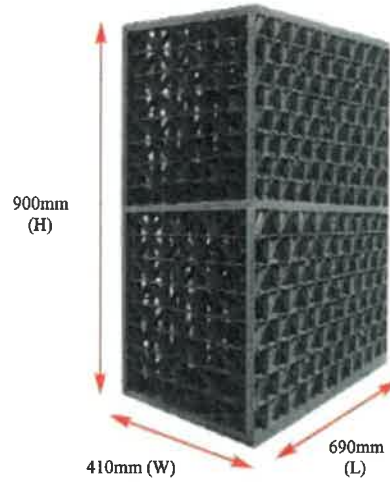

Double
4 Modules/m³
Flowrate - 4600 I/min

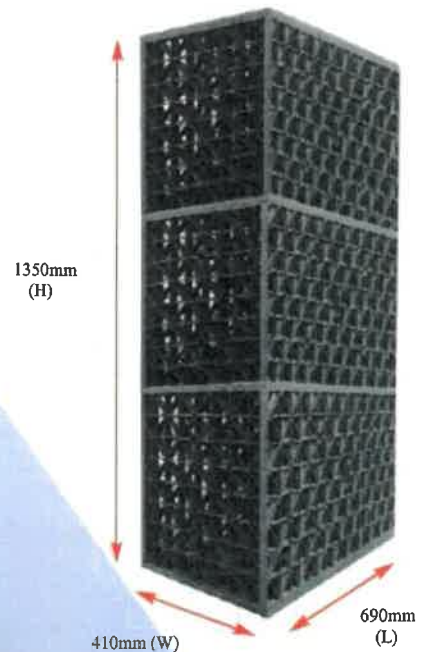

Triple
2.6 Modules/m³
Flowrate - 6900 I/min

Notes:

Blocks must be positioned in the correct orientation.
See opposite above

SPECIFICATION (SINGLE)

Weight (maximum)	9.17kg
Crush Strength (up to)	400kN/m ²
Lateral Strength	80kN/m ²
Minimum Cover (green areas)	500mm
(trafficked areas)	650mm
Maximum Cover	3m
Material	Polypropylene
Void Ratio (Internal)	>95%

Design Requirements:

- Tank storage capacity (m³)
- Depth restrictions
- Location (Road, Car Park, Green Area)
- Design constraints on site

A set of loading calculations specific to the site requirement will be done by ESS and submitted on all tanks

DESIGN CRITERIA

The attenuation tank is constructed using matrix module blocks. These blocks can take passing loads of up to 40 tonnes/m². The void ratio of each block is 95%. The blocks are made from polypropylene.

The tank is sealed with a layer of Tuflex membrane, which is fully welded together to form a 100% seal. All pipe penetrations are fully sealed to the membrane. The Tuflex membrane is protected by a layer of heavy duty protection geotextile, to prevent damage from construction or backfilling. A number of air extraction vents/flushing points are placed in the roof of the tank.

Note:

It is vital that the underground tanks are fully sealed, otherwise ground water and silt particles may enter the void space and use up capacity. Preferably, the base of the tank should be 500mm above the ground water level. Otherwise ground water relief measures should be implemented.

Infiltration Swales & Underground Channels

Please refer to separate data sheets for the following products

Modular VersaVoid System

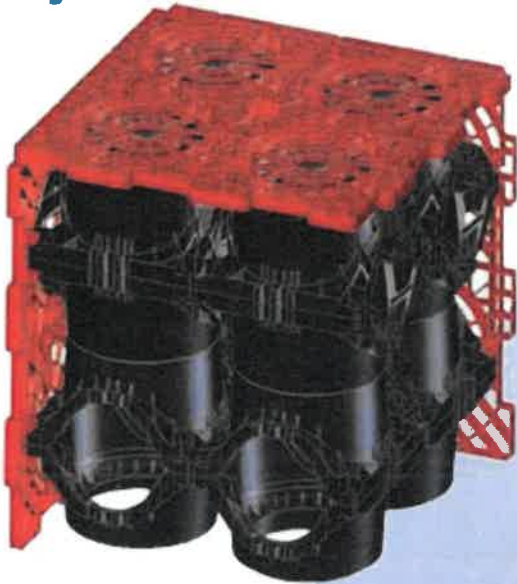

Benefits

- Ⓒ **Quick**
Reduce site access delays
- Ⓒ **Lightweight**
No cranes required
- Ⓒ **Strong**
Designed for maximum anticipated loads
- Ⓒ **Maintenance Free Tank**
All debris and sediment is pre-filtered
- Ⓒ **Determinate Volume**
One cubic metre of Tank modules contain 950 litres of water
- Ⓒ **Cost Effective**
Reduces excavation and disposal by up to 5 x compared with conventional soak wells
- Ⓒ **High Infiltration**
98% void surface area
- Ⓒ **Totally Modular**
For greatest flexibility designed to cope. Units start at 300mm deep

for shallow inverts to 3050mm+ deep in 250mm increments.

- Ⓒ **Designed by Engineers for Engineers** – to specify with confidence.
- Ⓒ **Designing out Problems** with such systems (access, maintenance, loading etc.)
- Ⓒ **Designing in Answers** to design requirements.
- Ⓒ **Total 3D Access**
For total maintenance with total confidence.
- Ⓒ **Structurally Designed** with built in safety factor to carry all loads with complete confidence.
16 clear vertical access chambers per m².
- Ⓒ **Total Void Creation**
With the greatest strength from any modular systems.

Oil Filtration

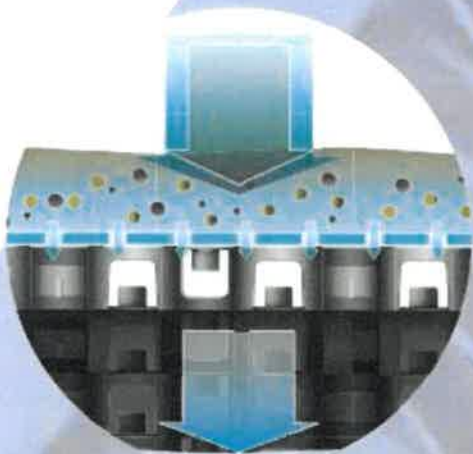

Benefits

- Ⓒ Source control designed to handle catastrophic spillages
- Ⓒ Capture, filter and break down residual hydrocarbons - all in one compact unit
- Ⓒ Self-maintaining ecosystems decompose hydrocarbon compounds and clean filters
- Ⓒ Load bearing, modular components provide up to 200t/m² loading capacity

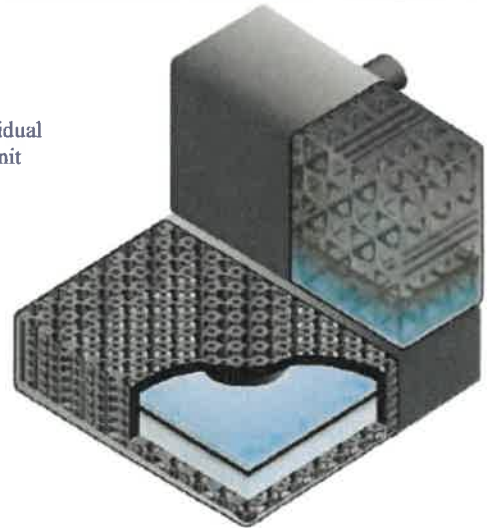

Aquabrake

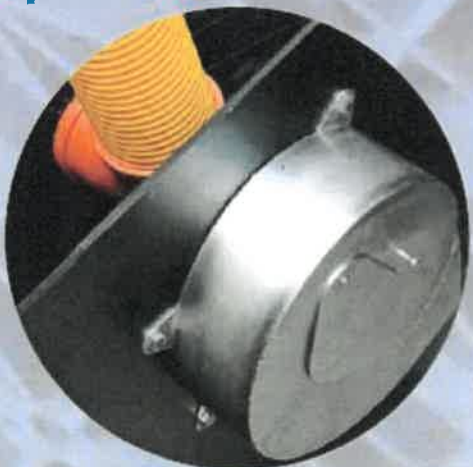

Benefits

- Ⓒ **Cost Savings**
Can reduce upstream storage requirements by up to 30%.
- Ⓒ **Durability**
Corrosion resistant stainless steel.
- Ⓒ **No energy requirements**
Self-activating solution with no moving parts.
- Ⓒ **Clog Resistant**
AquaBrake design prevents blockages likely to occur in traditional orifices.
- Ⓒ **Flexible Design**
Several options for attachment available.

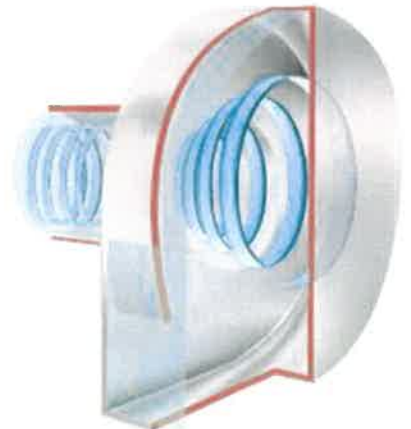

The ESS CombiSwale

Please refer to separate data sheets for the following products

Water Sensitive Urban Channels

Surface and Sub-Surface Water Treatment

By combining surface and sub-surface channeling and treatment solutions, ESS has created the ideal in bioswale water management.

The CombiSwale system includes the addition of permeable sub-surface waterways that further restore water quality and recharge the natural environment. The sub-surface ESS channel system provides a unique way of working with nature to solve the enormous problems currently associated with open

concrete channels and swales.

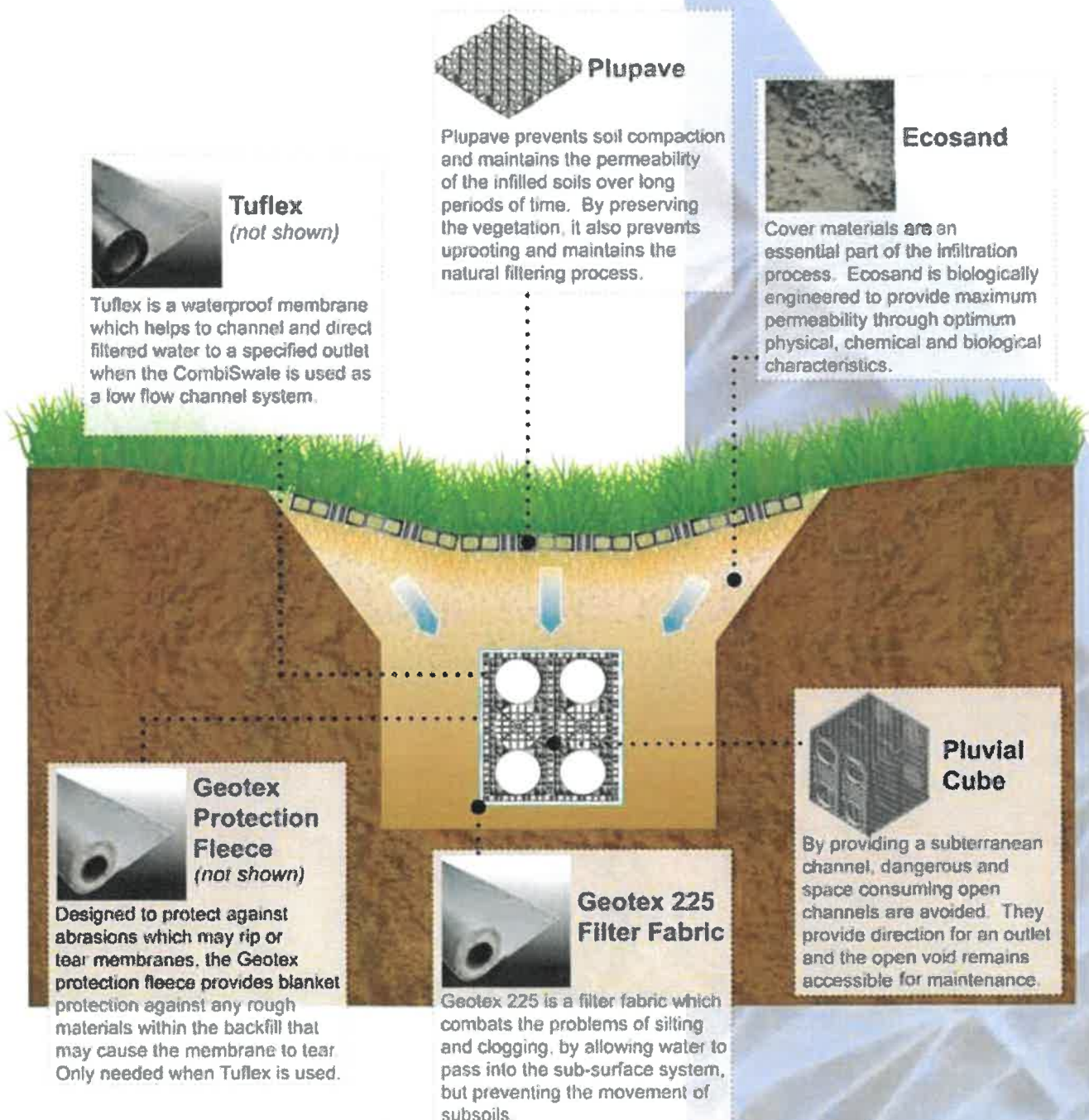

All products are manufactured to the highest quality, being subject to rigid quality control. However, the company cannot control conditions of application and use of its products, thus any warranty, written or implied, is given in good faith for materials only. ESS Ltd will not accept any responsibility for damage or injury arising from storage handling, misapplication or misuse of its products All transactions are subject to our standard condition of sale, copies of which are available on request.

